

SONY®

NTSC

Video Network Station

SNT-V704



IPELA™

INTEGRATED VISUAL COMMUNICATION

IPELA

IPELA is Sony's vision of the ultimate workplace, designed to revolutionize the way business communicates over global IP networks. Utilizing Sony's line of high quality, IP-ready videoconferencing and monitoring products, communication is delivered in high-resolution images and naturally clear audio – with a quality never before achieved.

The SNT-V704 is a compact, high-performance Video Network Station that allows users to remotely monitor and control analog cameras over a TCP/IP network. The unit accepts up to four analog video inputs providing outstanding flexibility for IP-based monitoring systems.

Supporting both MPEG-4 video and JPEG compressed images at a high-refresh rate of 30 fps (NTSC), the SNT-V704 offers the option to choose high video throughput over your network with MPEG-4 or high-quality still images with JPEG. USB support for additional storage, a bi-directional audio function, plus a number of other convenient features such as alarm, image transfer, and network security functions, enables scalable and effective monitoring operations.

If converting existing analog cameras to an IP-based monitoring system is needed, the SNT-V704 is your answer.

FEATURES

Analog Camera Monitoring/Control Via Network

The SNT-V704 Video Network Station supports TCP/IP protocol, enabling images from up to four analog cameras to be remotely monitored and the cameras to be controlled over LANs (Local Area Networks) and WANs (Wide Area Networks). Equipped with a built-in web server, the SNT-V704 allows users to monitor live images and to adjust settings of connected cameras via a PC running the Microsoft Internet Explorer® web browser; no additional software is required. A variety of display patterns and viewer window sizes are available. And up to 50 users can simultaneously monitor camera images.



MPEG-4/JPEG Support

Both MPEG-4 and JPEG are supported by the SNT-V704. Users have the option of selecting the bandwidth efficient MPEG-4 compression scheme or the industry standard JPEG compression scheme. The high performance SNT-V704 provides independent streaming of data from the analog ports at up to 30 fps, VGA (640 x 480) image size, for each port, greatly enhancing the capability of the IP monitoring system.

Bi-Directional Audio Function

The SNT-V704 is equipped with an external mic input that can be used to connect a microphone to the unit so that audio can be monitored from a remote PC. The unit also has an audio line output for active speakers, enabling users to make an announcement from the remote PC, significantly expanding the possibilities for remote monitoring applications.

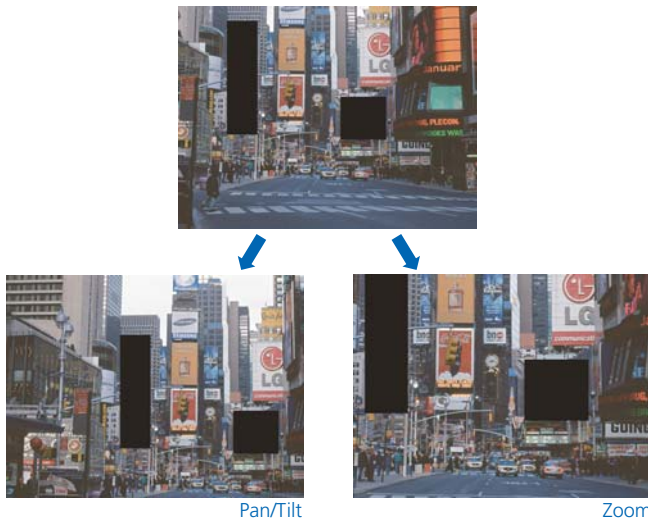

Fig 1 Dynamic Masking Function

USB Port for External Data Storage

Data storage capacity can be increased with either an external HDD (Hard Disk Drive) or USB flash memory device. Both MPEG-4 and JPEG compressed images can be recorded to the external storage device and viewed from the PC.*¹ Periodic recording is possible and pre-/post-alarm images can also be recorded.

*¹ Viewing MPEG-4 files requires the supplied application software.

Alarm Function

The SNT-V704 is equipped with a built-in, activity-detection function that can be set to generate an alarm through its alarm-output ports. Up to two detection areas can be set for each camera. In addition, with a sensor-input port that can receive a trigger from an external sensor and a built-in 32-MB buffer, the SNT-V704 can store hundreds of pre-alarm and post-alarm still images at the time an alarm is triggered – whether from the activity-detection function, the alarm-input port, or both. Pre-/post-alarm images can then be transferred to an FTP server or recorded to an external storage device. Also, if desired, the image acquired at the time of an alarm event can be sent to pre-designated e-mail addresses.

Serial Interface (RS-232C/485/422)

Using the SNT-V704 serial interface, camera Pan/Tilt/Zoom (PTZ) control and limited camera setting adjustments can be made.*²

*² Contact your local Sony sales office for a list of cameras that can be controlled.

Network Security Feature

User access to video cameras via the SNT-V704 can be limited by IP filtering. Up to ten different groups can be established by defining an IP address for each group. Additionally, user names and passwords can be assigned to allow four levels of access.

Dynamic Masking Function Fig 1

Up to two areas rectangular in shape within each camera image can be masked. Even if a camera pans, tilts, or zooms, the masked area will remain concealed.

OTHER FEATURES

"Tour" Feature

Allows a user to preset up to five scanning patterns with up to 16 positions in each scan.

"Area Setting" Feature

Allows the administrator to crop an area within an image, which is particularly useful when monitoring a specific area within that image if needed.

Compact and Lightweight Design

With its small size and light weight, the SNT-V704 is suitable for installation in small spaces. Of course, rack mounting is also an option.

Easy Setup Fig 2

The SNT-V704 is easy to set up with the intuitive setup menu.

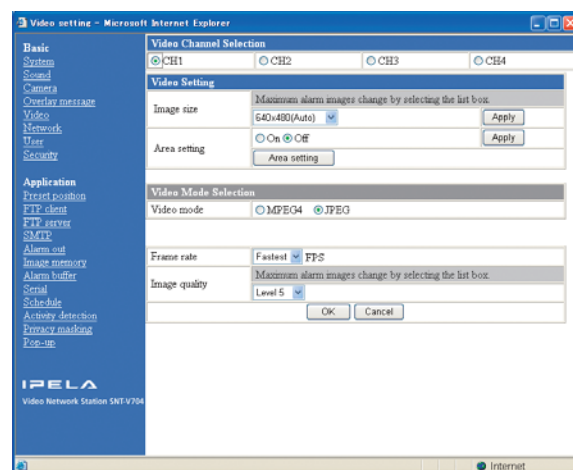
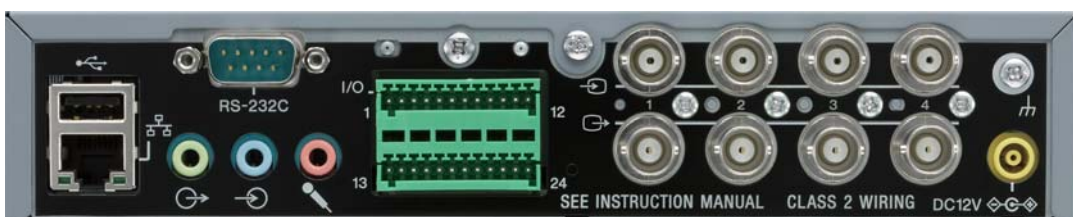
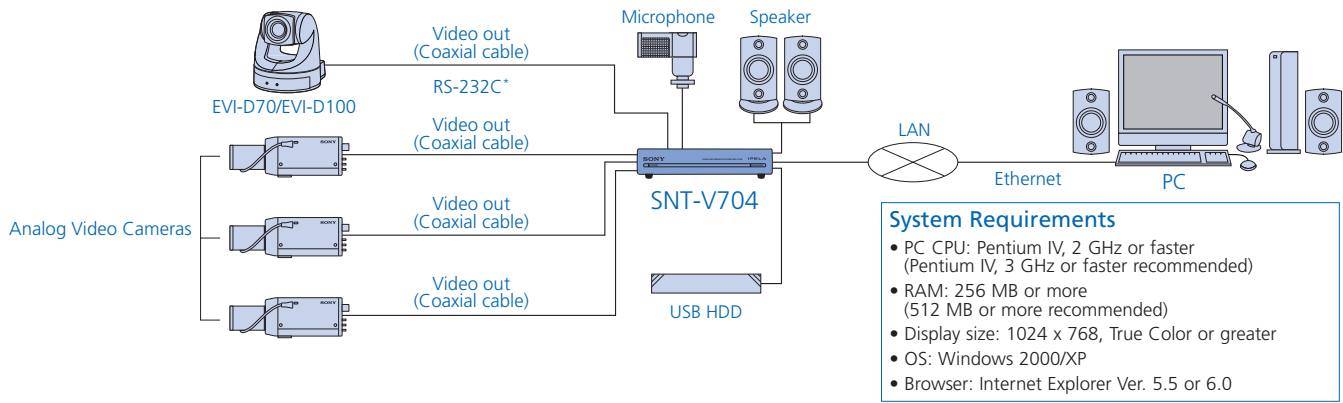

Fig 2 Setup Menu



SNT-V704 Rear Panel

SYSTEM CONFIGURATION



- System Requirements**
- PC CPU: Pentium IV, 2 GHz or faster (Pentium IV, 3 GHz or faster recommended)
 - RAM: 256 MB or more (512 MB or more recommended)
 - Display size: 1024 x 768, True Color or greater
 - OS: Windows 2000/XP
 - Browser: Internet Explorer Ver. 5.5 or 6.0

SPECIFICATIONS

SNT-V704	
Analog Video Interface	
Video input	Analog composite (BNC x 4), 1.0 Vp-p, 75 Ω, unbalanced, sync negative, Auto sensor for NTSC or PAL
Video output	Analog composite (BNC x 4), 1.0 Vp-p, 75 Ω, unbalanced, sync negative (loop-through)
Audio	
Audio compression	G.711 (64Kb/s)
Mic in	Mini-jack (Monaural) Supports Plug-in power system (5.0 V DC)
Line out	Mini-jack (Monaural x 2ch) Maximum output level 1.1 Vrms
Line in	Mini-jack (Monaural x 2ch) Maximum output level 1.1 Vrms
System/Network	
CPU	64-bit RISC processor
RAM	128 MB (including 32 MB alarm buffer)
Flash memory	32 MB
Image size (JPEG/MPEG-4)	NTSC: 720 x 480, 640 x 480, 320 x 240 PAL: 720 x 576, 640 x 480, 320 x 240
Compression	JPEG/MPEG-4
Compression ratio	Variable in*
Frame rate (JPEG/MPEG-4)	NTSC: Max. 30 fps x 4ch (640 x 480)
Protocols	TCP/IP, ARP, ICMP, HTTP, FTP (server/client), SMTP, DHCP, DNS, NTP, SNMP (MIB-2)
Number of clients	Max. 50
Interface	
Ethernet	100Base-TX/10Base-T (RJ-45)
Sensor input	4 (3.3 to 24 V device supported, photocoupler inputs are electrically isolated from the unit)
Alarm output	4 (24 V DC or less, 1A, mechanical relay outputs are electrically isolated from the unit)
Serial interface	RS-232C/485/422 (for camera control)
USB Port	USB 2.0 (for use with USB mass storage class devices only)
General	
Weight	Approx. 2 lb 10 oz (1.2 kg)
Dimensions(W/H/D)	8 3/8 x 1 11/16 x 8 inches (210 x 42 x 202 mm)
Power requirements	DC 12 V (AC adaptor included)
Power consumption	18 W
Operating temperature	14°F to 122°F (-10°C to 40°)
Storage temperature	-4°F to 140°F (-20°C to 60°C)
Operating humidity	20 to 80 %, Non-condensing
Storage humidity	20 to 95 %, Non-condensing
Supplied accessories	CD-ROM (setup program and User's Guide) (1), I/O receptacle (2), AC adaptor, AC cord, Installation manual (1)

* The compression ratio is based on an image of 24 bits per picture element (8 bits for each R, G and B).

DIMENSIONS

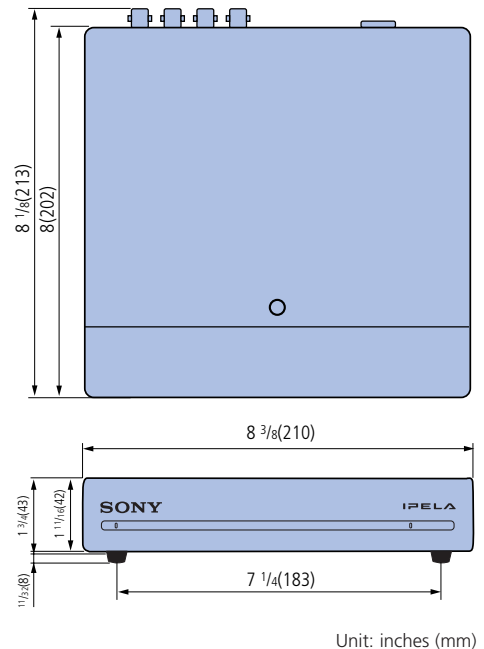

Unit: inches (mm)

SONY®

Sony Electronics Inc.
1 Sony Drive
Park Ridge, NJ 07656
www.sony.com/security

S-SNTV704
MK10252V1

©2005 Sony Corporation. All rights reserved.
Reproduction in whole or in part without written permission is prohibited.
Features and specifications are subject to change without notice.
All non-metric weights and measurements are approximate.
Some images in this catalog are simulated.
Sony and IPELA are trademarks of Sony.
Internet Explorer is a trademark of Microsoft Corporation.



Printed in USA (4/05)