

SONY

Intelligent Communication Color Video Camera

EVI-D30(NTSC) ***EVI-D31(PAL)***

Component/OEM



EVI-D30/D31 is a pan/tilt video camera with highly sophisticated image processing technology which enables target objects to be recognised.

- High speed, Wide Range Pan/tilter
- X12 Optical Zoom, High Speed Auto-Focus Lens
- 6 Position Preset
- Auto Tracking / Motion Detector
- RS232C Serial Control (VISCA)
- IR remote Commander
- Time, Date Generator

Specification

	EVI-D30	EVI-D31
Video Signal	NTSC	PAL
Image Sensor	1/3"IT Color CCD	
Effective Pixels	768(H)X492(V)	752(H)X585(V)
H. Resolution	460TV lines	450TV lines
V. Resolution	350TV lines	400TV lines
Lens	X12 Power Zoom, ~f=5.4~64.8mm, F1.8~F2.7	
H. Angle of View	4.4~48.8degrees	
Shortest Subject Dist	10mm(WIDE end)、800mm(TELE end)	
Min. Illumination	7lux(F1.8)	
Illumination Range	7~100,000lux	
Auto Exposure	Auto Iris, AGC	
Shutter Speed	1/60~1/10,000(VISCA control)	1/50~1/10,000(VISCA control)
Gain	Auto/Manual(VISCA control)	
White Balance	TTL Auto Tracing/One Push Hold, Indoor Preset, Outdoor Preset(VISCA control)	
S/N Ratio	more than 48dB	
Pan/Tilt	Horizontal ± 100 degree(Max speed 80degree/sec), Vertical ± 25 degree (Max speed 50degree/sec)	
Video Output	RCA pin jack, 1Vp-p, 75ohm unbalanced	
S Video Output	4 pin mini DIN	
Audio Output	RCA pin jack (monaural), Rated output 327mV, Output impedance less than 2.2 kilohms	
Control Terminal	RS232C, 8 pin mini DIN, 9600bps, Data 8 bit, Stop 1 bit	
Microphone Input Terminal	Mini jack(monaural)($\phi 3.5$), Rated input 0.775mV DC3V for low impedance microphone, Input Impedance more than 10k Ω	
Power Terminal	DC IN 13.5V(EIAJ unified polarity type)	
Power Requirements	DC 12~14V	
Power Consumption	10.5W	
Operating Temperature	0~40°C	
Storage Temperature	-20~60°C	
Dimensions(W/H/D)	Camera 142x109x164mm、 Remote Commander 56x26x210mm	
Mass	Camera 1200g、 Remote Commander 109g	
Supplied Accessories	AC Power Adapter, AV cable, Remote Commander, Velcro Tape, Operating Instruction	

Dimensions

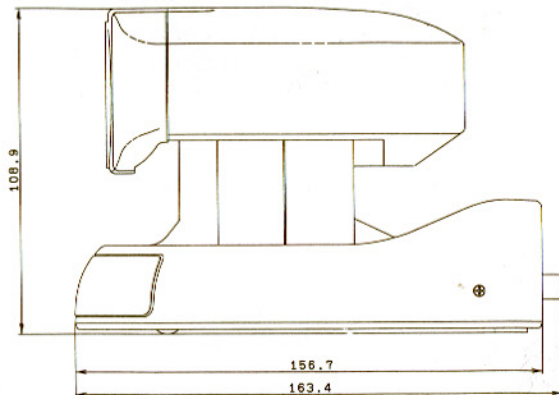
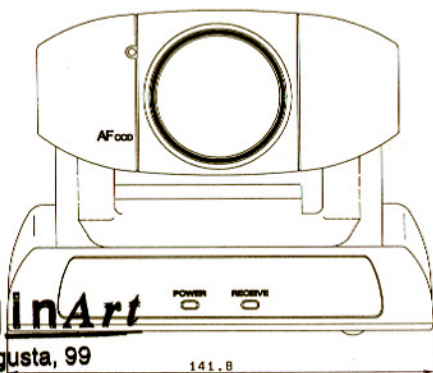

ImaginArt
 Via Augusta, 99
 08006 BARCELONA
 Tel. (93) 292 07 70
 Fax (93) 217 76 51

<p>Sony Electronics Inc. ISP (USA) Itasca, IL San Jose, CA Montvale, NJ</p> <p>Sony of Canada Ltd.(CANADA) Sony Broadcast & Professional Europe HQ (The Netherlands) Germany France UK Nordic Italy</p> <p>Sony Corp. Isc Co. APP Sales Dpt. (JAPAN)</p>	<p>1200 North Arlington Heights Rd. Itasca, IL 60143 3300 Zanker Rd. San Jose, CA 95134-1901 3 Paragon Dr. MD-S131 Montvale, NJ 07645 411 Gordon Baker Rd. Willowdale, Ontario M2H 2S6</p> <p>Schipholwed 275 1171 PK Badhoevedorp Hugo-Eckener-Str. 21, 50829 Koln 15 rue Floreal 75831 Paris Cedex 17 The Height, Brooklands Weybridge Surrey, KT13 0XW Per Albin Hanssons vag 20-S-214 32 Malmö Via Galileo Galilei 40 I-20092 Cinisello Balsamo, Milano 4-16-1 Okata, Atsugi-shi, Kanagawa-Ken, 243</p>	<p>TEL:630-773-7604 TEL:408-955-5623 TEL:201-358-4180 TEL:416-499-1414</p> <p>TEL:20-6581148 TEL:0-221-5966-8846 TEL:1-40-87-31-26 TEL:01932-816300 TEL:040-19-08-00 TEL:02-618-381 TEL:0-462-27-2345</p>	<p>FAX:630-773-7605 FAX:408-955-5630 FAX:201-358-4401 FAX:416-497-1774</p> <p>FAX:20-6581912 FAX:0-221-5966-491 FAX:1-40-10-94-18 FAX:01932-817017 FAX:040-19-04-50 FAX:02-618-38-402 FAX:0-462-27-2347</p>
---	--	--	--

AT(Auto Tracing)Mode

AT is a function which continually extracts a subject that the user pre-defines. After picking up pixels of similar color and brightness around the selected subject, EVI-D30/D31 extracts the target by using the subject model based on light reflection and nonlinear camera processing. There are four modes for pre-defining the subject.

●AT-PAN/TILT

This function follows the moving subject automatically by controlling the pan&tilt motors without the use of special sensors.

●AUTO ZOOM

This function automatically controls the zoom lens to ensure that the size of the subject remains constant.

●ATAE

The EVI-D30/D31 employs the auto exposure and advanced backlight compensation systems to ensure that the subject remains bright even in harsh backlight conditions. Because the subject position is known a comparison can be made between its brightness and that of the background and the camera subsequently adjusted to compensate for the conditions.

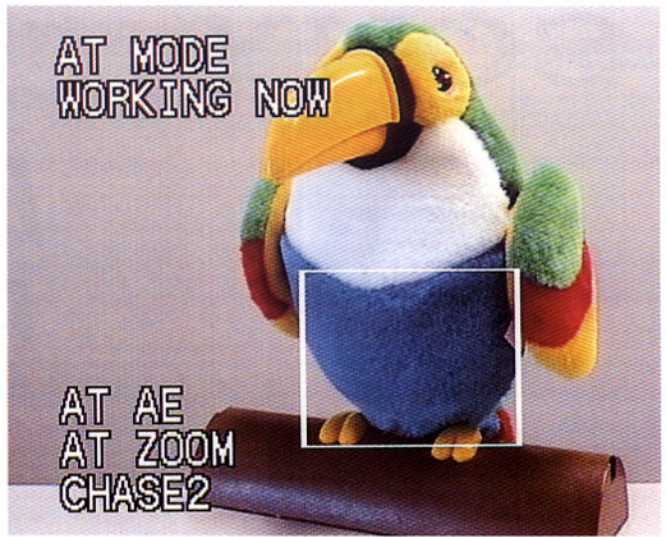

MD(Motion Detector)Mode

MD basically detects the difference between the initial reference image and the current image.

The conventional technique employed in MD uses only the brightness of the video signal. The EVI-D30/D31 uses both the brightness and color which enables even an object of the same brightness as the background to be detected.

●Changes in light conditions are constantly monitored and the data in the reference image adjusted.

●A user can set two rectangular detection areas of any size and in any position of the scene.

●Once motion is detected within the preselected windows an alarm signal is output which, for example, can commence the recording on a VCR.

●This mode is made even more versatile by the ability to adjust the detection brightness, color and area.

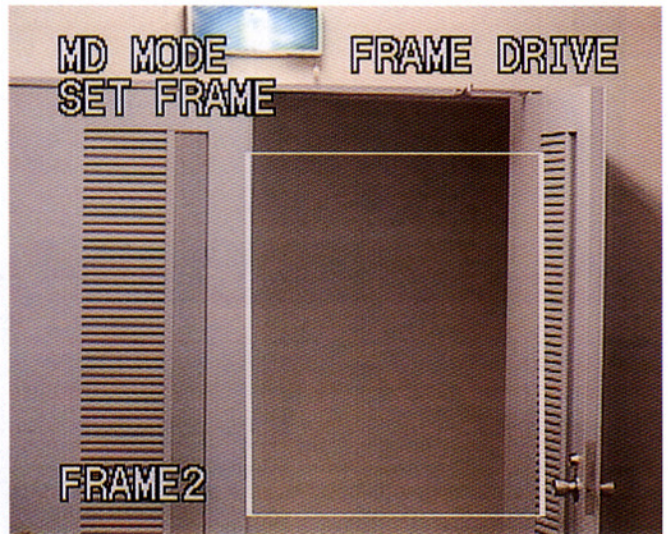

Supplied Accessory

- AC Power Adapter
- AV Cable
- IR Remote Commander

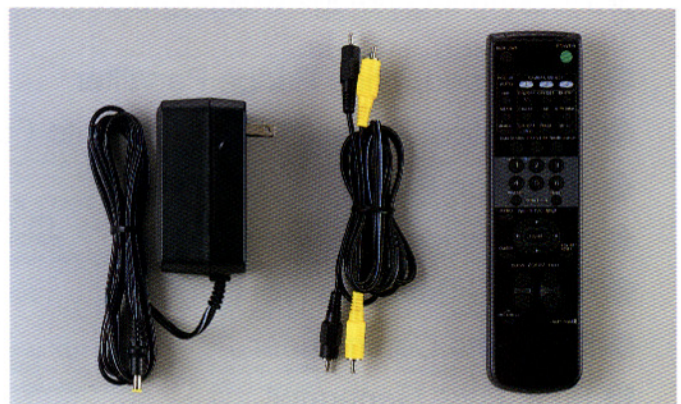

Connection

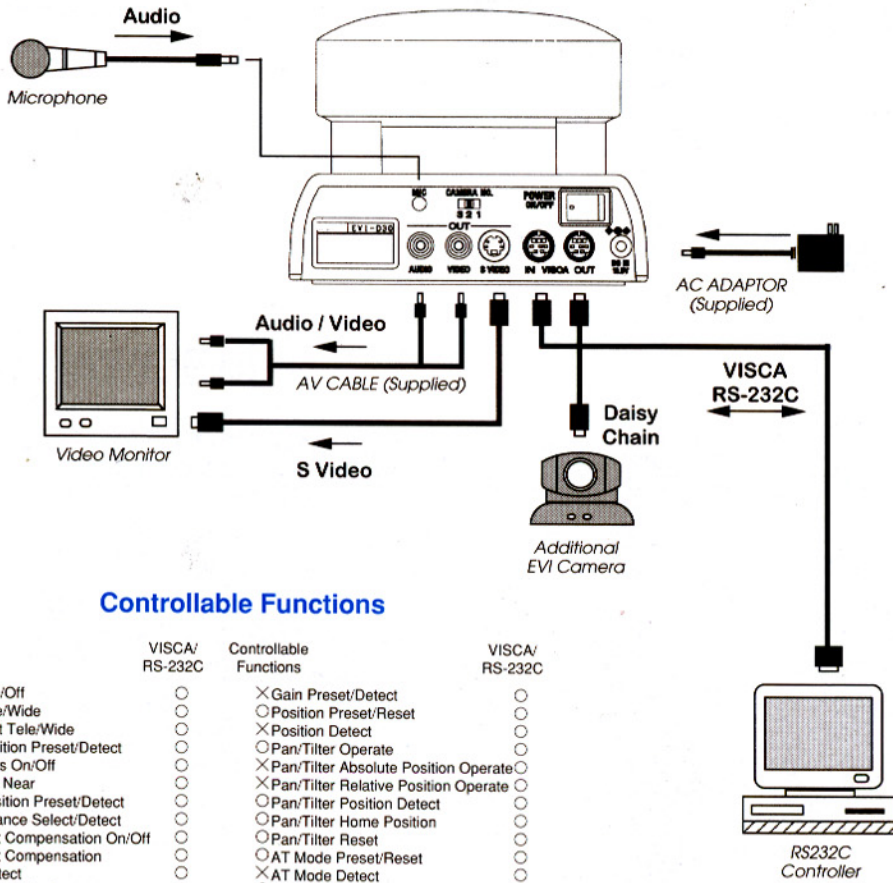

Controllable Functions

Controllable Functions	VISCA/RS-232C	Controllable Functions	VISCA/RS-232C
<input type="radio"/> Power ON/Off	<input type="radio"/>	<input checked="" type="checkbox"/> Gain Preset/Detect	<input type="radio"/>
<input type="radio"/> Zoom Tele/Wide	<input type="radio"/>	<input type="radio"/> Position Preset/Reset	<input type="radio"/>
<input type="radio"/> Zoom Fast Tele/Wide	<input type="radio"/>	<input checked="" type="checkbox"/> Position Detect	<input type="radio"/>
<input checked="" type="checkbox"/> Zoom Position Preset/Detect	<input type="radio"/>	<input type="radio"/> Pan/Tilt Operate	<input type="radio"/>
<input type="radio"/> Auto Focus On/Off	<input type="radio"/>	<input checked="" type="checkbox"/> Pan/Tilt Absolute Position Operate	<input type="radio"/>
<input type="radio"/> Focus Far Near	<input type="radio"/>	<input checked="" type="checkbox"/> Pan/Tilt Relative Position Operate	<input type="radio"/>
<input checked="" type="checkbox"/> Focus Position Preset/Detect	<input type="radio"/>	<input type="radio"/> Pan/Tilt Position Detect	<input type="radio"/>
<input checked="" type="checkbox"/> White Balance Select/Detect	<input type="radio"/>	<input type="radio"/> Pan/Tilt Home Position	<input type="radio"/>
<input type="radio"/> Back Light Compensation On/Off	<input type="radio"/>	<input type="radio"/> Pan/Tilt Reset	<input type="radio"/>
<input checked="" type="checkbox"/> Back Light Compensation	<input type="radio"/>	<input type="radio"/> AT Mode Preset/Reset	<input type="radio"/>
<input checked="" type="checkbox"/> Preset/Detect	<input type="radio"/>	<input checked="" type="checkbox"/> AT Mode Detect	<input type="radio"/>
<input checked="" type="checkbox"/> Bright Control Up/Down	<input type="radio"/>	<input type="radio"/> MD Mode Preset/Reset	<input type="radio"/>
<input checked="" type="checkbox"/> Shutter Speed Preset/Detect	<input type="radio"/>	<input checked="" type="checkbox"/> MD Mode Detect	<input type="radio"/>
<input checked="" type="checkbox"/> Iris Preset/Detect	<input type="radio"/>		

VISCA

EVI-D30/D31 can be controlled by RS232C serial control using VISCA.

9600 baud, data length of 8 bits, 1 stop bit, and no parity.

VISCA is an acronym of Video System Control Architecture. It is a network protocol designed to interface a wide variety of video equipment to computer.

Under VISCA, up to 7 EVI-D30/D31 can be connected to one controller using RS232C communication. RS232C parameters are communications speed of

Pan/Tilt Range

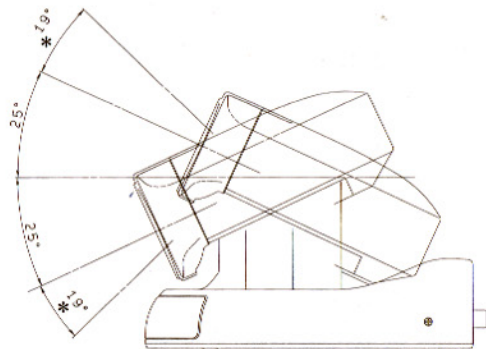
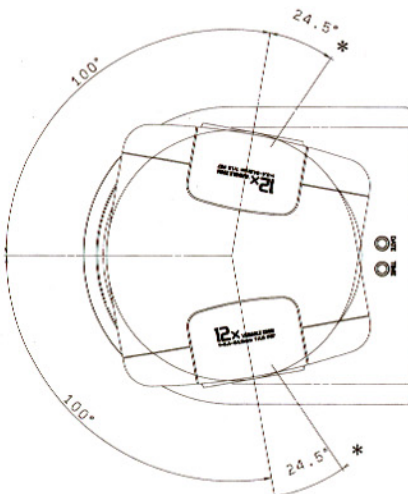

*:Angle of view